



KL 152

FABBRICATORI DI GHIACCIO IN CUBETTI
 MACHINES À GLAÇONS
 ICE CUBE MACHINES
 FABRICADORES DE HIELO EN CUBITOS
 EISWÜRFELBEREITER

SERIE KL 18 20 22 32 42 52 62 72 102 132 152 172 302



**Stainless steel
 AISI 304**

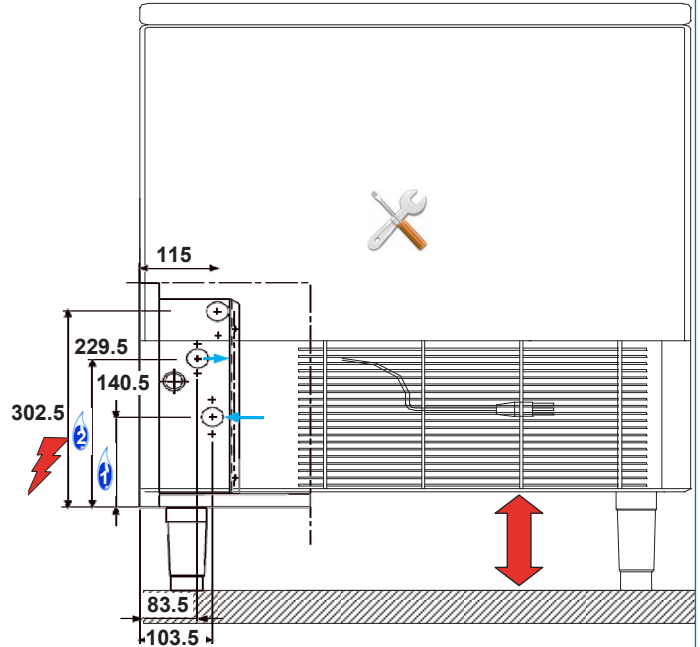

L=1800 mm		
ø 3/4"		
ø 3/4"		
130÷140 mm		



Kg / 24h - Air				
	38°	90	32°	
	32°	114	21°	
	21°	135	15°	
	10°	145	10°	

Kg / 24h - Water				
	38°	106	32°	
	32°	127	21°	
	21°	137	15°	
	10°	147	10°	



Filter
 a richiesta
 sur demande
 on request
 a petición
 auf Anfrage

KL 32F - KL 42F

a richiesta • sur demande • on request
 a petición • auf Anfrage

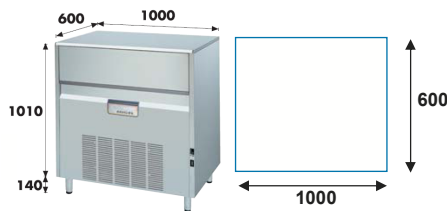

Stainless steel AISI 304



Ø 27 x 32



Air



Water

KL 152

FABBRICATORI DI GHIACCIO IN CUBETTI
MACHINES À GLAÇONS
ICE CUBE MACHINES
FABRICADORES DE HIELO EN CUBITOS
EISWÜRFELBEREITER

Dati tecnici – Caractéristiques techniques – Technical specifications – Datos técnicos – Technische Daten

Prod.Kg/24h +10°C - Prod.Lb/24h +10°C		145-319
Prod.Kg/24h +10°C - Prod.Lb/24h +10°C		147-324
Cubetti/Glaçons /cubes/cubitos/Würfel - n° /24h		8050
Cubetti/Glaçons /cubes/cubitos/Würfel - n° /24h		8160
Contenitore/Bac/Bin/Depósito/Behälter	Kg/Lb	65-143
Cubetti contenitore/Glaçons bac/Bin cubes/Depósito cubitos/Würfel Behälter	N°	3610
Dimensione cubetto/Dimensions glaçons/Cubes sizing/Dim. cubitos/Würfelgröße	mm Ø	27x32
Larghezza/Largeur/Width/Anchura/Breite	mm	1000
Profondità/Profondeur/Depth/Profundidad/Tiefe	mm	600
Altezza/Hauteur/Height/Altura/Höhe	mm	1010
Peso netto/Poids net/Net weight/Peso neto/Nettogewicht	Kg	101
Peso lordo/Poids brut/Gross weight/Peso bruto/Bruttogewicht	Kg	105
Vol. imballo/Vol.embal/Vol.(packed)/Volumen con embalaje/Verpackungsvolumen	m ³	0,82
Alimentazione/Voltage/Voltaje/Anschlussspannung	V/Hz/ph	230/50/1
Compressore/Compresseur/Compressor/Compresor/Kompressor	HP	1,2
Compressore/Compresseur/Compressor/Compresor/Kompressor (T = -15°C)	W	1850
Watt - Totale/Total/Total/Total/Gesaint (T = +43°C)	W	1350
Calorie/Calorie/Calorie/Caloria/Kalorie cond.	Kcal / h	2420
Ampère - Totale/Total/Total/Total/Gesamt	A	6,5
Fusibile/Fusible/Recommanded fuse/Fusible/Netzsicung	A	20
Refrigerante/Réfrigérant/Cooling gas/Refrigerante/Kühlmittel	R	290
Carica/Charge/Fill/Carga/Füllmenge	Kg	0,149
eq. CO ₂	Kg	0,447
GWP		3
Carica/Charge/Fill/Carga/Füllmenge	Kg	0,120
eq. CO ₂	Kg	0,360
GWP		3
Entrata acqua/Entrée eau/Water inlet/Entrada agua/Wasseranschluß	Ø	3/4"
Scarico acqua/Vidange eau/Water outlet/Desague/Wasserabfluß	Ø	3/4"
Acqua/Eau/Water/Agua/Wasser - lt / h 21°C / 15°C		16-46
Pressione acqua/Pression eau/Water pressure/Presión agua/Wasserdruck - bar	min / max	1 - 6
Temp.ambiente/Temp.ambiant/Ambient temp./Temp.ambiente/Rammtemperatur - °C	min / max	10 - 40
Temp. acqua/Temp. eau/Water temp./Temp. agua/Wassertemperatur - °C	min / max	5 - 35

