

# Instruction manual **BALI**

## 1. UNLOADING

The device should be transported in vertical position, and it should be properly secured and packed. The manufacturer ships the device on a special wooden platform, secured with cardboard angle sections and foil.

## 2. PROPERTIES OF THE DEVICE

### 2.1. Purpose

The „BALI” display rack is a universal cooling device designed for the storage and exhibition of a wide range of food products previously cooled to the storage temperature. Guaranteed temperature inside the counter +2°C/+8°C at ambient temperature +15°C/+25°C and relative humidity up to 60%.

### 2.2. Description of the device

The „BALI” display racks have a dynamic cooling system. All types are equipped with an automatic defrosting system and an electronic thermostat optionally cooperating with a temperature recording module allowing for the recording and signaling of excessively high and excessively low temperatures inside the device. They can also be equipped with the automatic evaporation of condensation as an option. The devices are adapted to connecting in sequences, in a version with an internal cooling unit (mod/A) or with a central cooling unit (mod/C). The racks are equipped with 4 or 5 exhibition shelves (depending on the type of device, mod/C - 5 shelves), with adjustable height and suspension angle. Optional equipment includes meat hooks or fruit and vegetable baskets. The interior of the rack is illuminated. It is also possible to install additional illumination for each shelf. All „IGLOO” devices are manufactured according to modern technologies and have all the legally required certificates.

## Contents

1. UNLOADING	11
2. PROPERTIES OF THE DEVICE	11
2.1. Purpose	11
2.2. Description of the device	11
2.3. Technical data	12
3. PREPARING THE DEVICE FOR EXPLOITATION	13
3.1. Requirements concerning the place of installation	13
3.2. Connection and actuation	13
4. EXPLOITATION	15
4.1. Temperature regulation	16
5. MAINTENANCE	16
5.1. Cleaning and maintenance	16
6. SERVICE	18
6.1. Fault identification and repair	18
6.2. Service	20
7. THERMOSTAT SERVICE	20
7.1. „IGLOO” thermostat	20
7.2. „CAREL” thermostat	21

## List of Figures

Fig.1 Construction of the device	12
Fig.2 Removing the wooden platform	14
Fig.3 Fixing the hook in the frame	14
Fig.4 Rack shelf set	14
Fig.5 Meat hooks rail	15
Fig.6 Fruit and vegetable baskets	15
Fig.7 Control panel	15
Fig.8 Condensate container	17
Fig.9 Cleaning the condenser	17
Fig.10 Changing the fluorescent lamp	18
Fig.11 Data plate	20
Fig.12 „Iglloo” thermostat control panel	20
Fig.13 „Carel” thermostat control panel	21

## List of tables

Table.1 Technical data	12
------------------------	----



This sign signifies information of particular meaning for user security and for proper device exploitation.

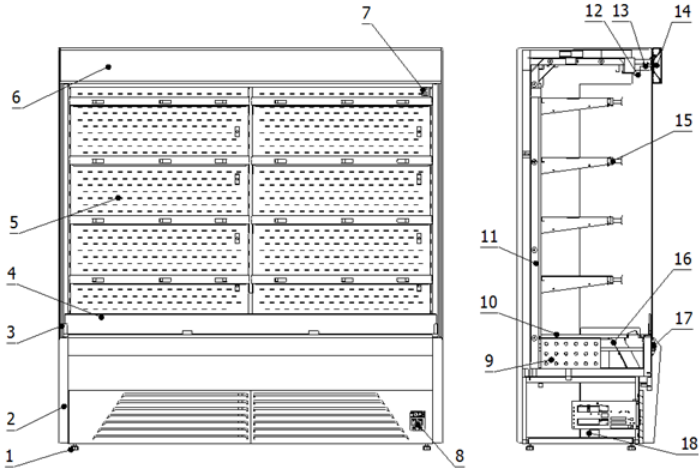

Fig.1 Structure of the device

- 1- device leveling legs
- 2- side panels
- 3- glass sides
- 4- front screen (only open devices)
- 5- device screen
- 6- top panel
- 7- nameplate
- 8- control panel
- 9- evaporator

- 10- bottom shelves
- 11- frame
- 12- top internal illumination
- 13- night roller blind manual
- 14- panel illumination
- 15- exposition shelf with height and angle adjustment
- 16- ventialotrs plate
- 17- front bumper
- 18- agregate

2.3. Technical data

Table 1 Technical data

Type of the device "BALI"	Rated voltage [V/Hz]	Rated current [A]	Rated lighting power [W]	Electric energy consumption [kWh/24h]	Cooling power demand [W/mb]	Max shelf load [kg/mb]	Weight of the device [kg]
1.0	230/50	3,2	28,8	15,8	-	33	150
1.3	230/50	3,3	34	20,2	-	33	180
1.6	230/50	4,2	44,8	24,9	-	33	210
1.9	230/50	4,5	57,6	25,4	-	33	250
2.5	230/50	5,5	68	30,7	-	33	290
1.0 - mod/A	230/50	3,2	28,8	15,8	-	33	130
1.3 - mod/A	230/50	3,3	34	20,2	-	33	160
1.6 - mod/A	230/50	4,2	44,8	24,9	-	33	190
1.9 - mod/A	230/50	4,5	57,6	25,4	-	33	230
2.5 - mod/A	230/50	5,5	68	30,7	-	33	270
1.0 - mod/C	230/50	0,3	28,8	1,0	800	33	115
1.3 - mod/C	230/50	0,3	34	1,4	800	33	145
1.6 - mod/C	230/50	0,5	44,8	1,9	800	33	175

1.9 - mod/C	230/50	0,6	57,6	2,0	800	33	215
2.5 - mod/C	230/50	0,7	68	2,5	800	33	255

### 3. PREPARING THE DEVICE FOR EXPLOITATION

#### 3.1. Requirements concerning the place of installation

- Verify whether the cross section of feeding conduits is proper for power consumption of the installed device.
- It is forbidden to connect the device by extension rods or dividers.
- The device should be connected to the separate, properly made electric circuit with plug-in socket with protecting pin (according to PBUE /Regulations concerning Electric Equipment Construction/)

#### 3.2. Connection and actuation

- Unpack the device and remove the wooden platform from the basis Fig.3 (p.4)
- The device should be placed on an even and on a sufficiently hard base, and then level it with the help of levelling feet.
- Remove the protection foil from the elements of the device (f. ex. from the inside of the device, display shelves, front fender beam)
- If the user shall obtain a device partially disassembled to secure it during transportation, perform the following operations:
  1. Fix hooks in frame rails Fig.4 (p.14)
  2. Place shelves and/or baskets on hooks Fig.5 (p.14) and/or Fig.7 (p.15)
  3. (Concerns the devices with internal aggregate) Place the condensate container on the basis of the aggregate, under water outflow hose (does not concern devices with automatic condensate evaporation) Fig.9 (p.17)
  4. (Concerns the devices to be mounted on central aggregate) Defrosting water outflow is located under the bottom of the body (about 10mm from the back of the rack, in the middle part of the body), which needs to allow water outflow to the sewage grit.
- The first cleaning of the device should be provided right after unpacking, and before turning it on. The unit should be cleaned with water at a temperature not exceeding 40°C with a neutral detergent. For washing and cleaning the equipment it is prohibited to use products containing chlorine and sodium varieties, which destroy the protective layer and components of the device! Any residue of adhesives or silicone on metal elements should be removed only with extraction naphtha (not applicable to items made of plastic!). Do not use other organic solvents.



**When cleaning the unit is prohibited to use water jet. The unit should be cleaned with a wet rag.**



After installation of the device at the destination place it should be left to rest for at least 2 hours before turning it on (for devices with built-in compressor) to set the level of refrigerant in order to prevent problems with starting up the aggregate.

**WARNING: Keep out the cooling circuit from damage!**

- Place the plug of the connecting cable directly in plug-in socket (it is forbidden to connect the device by means of extension cords or dividers!)
- Turn on the main switch Fig.8/2 (p.15), which activates the thermostat, and then aggregate of the device
- Set the temperature on thermostat control panel Fig.8/1 (p.15) (thermostat service details on p.20 or 21)
- Turn on the lighting switch Fig.8/3 (p.15)

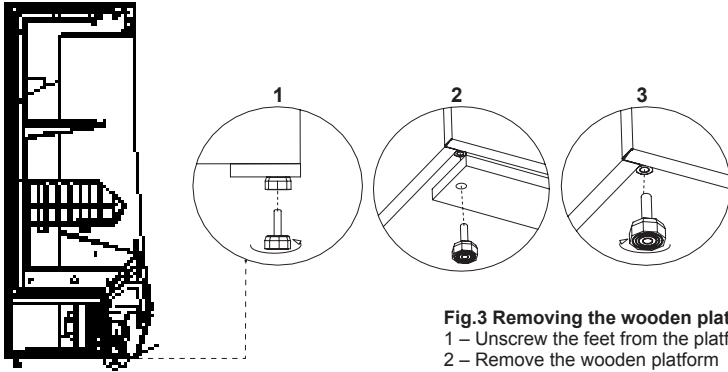
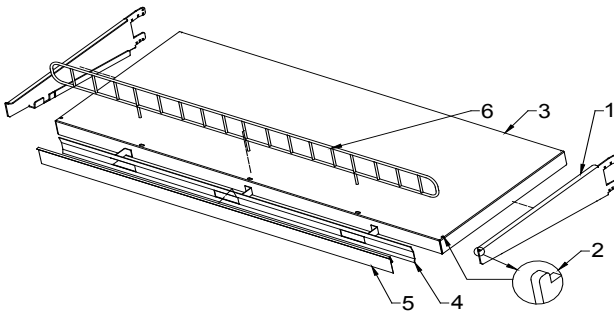
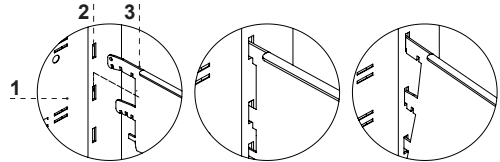

**Fig.3 Removing the wooden platform**

- 1 – Unscrew the feet from the platform
- 2 – Remove the wooden platform
- 3 – Screw the feet in nuts welded to the frame of the device

**Fig.4 Fixing the hook in the frame**

- 1 – Rack screen
- 2 – Hook fixing frame
- 3 – Hook (adjusted to three level angle regulation)



**Fig.5 Rack shelf set**

- 1 – Shelf hook
- 2 – Element securing the shelf against shifting
- 3 – Rack shelf
- 4 – Cool air steering wheel
- 5 – Shelf price strip
- 6 – Shelf limiter

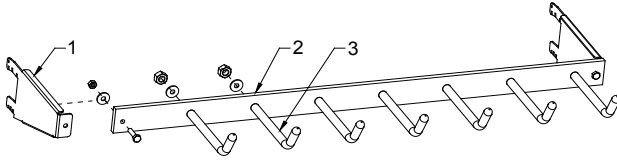

**Fig.6 Meat hooks rail**

- 1 – Hook under the meat hook rail
- 2 – Meat hook rail
- 3 – Meat hooks

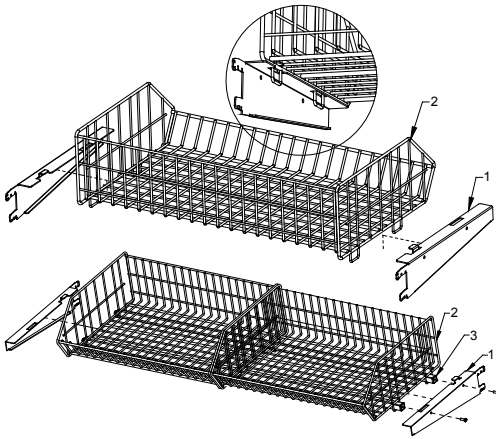

**Fig.7 Fruit and vegetable baskets**

- 1 – Basket hook
- 2 – Fruit and vegetable basket
- 3 – 20x20x2 closed steel profile connecting baskets (concerns racks 1.3 and 2.5)

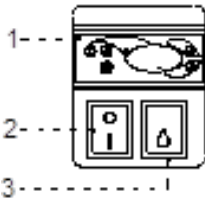

**Fig.8 Control panel**

- 1 – Thermostat (temperature regulator) panel  
(service details in Chapter No. 7 p.10 or 11)
- 2 – Main switch (turns on/off the aggregate of the device)
- 3 – Lighting switch

## 4. EXPLOITATION

Temperature of the cooled space and aggregate operating cycle may fluctuate. They depend on numerous factors, such as amount and temperature of products placed in the device and temperature of the surroundings.

The device should be placed in a dry and well-ventilated place, ensuring proper air exchange (distance between the wall and the device – min. 10 cm), out of sunlight, kept far from heat sources and devices enforcing air flow (ceiling and portable ventilators, blow-in heaters). The device functions properly in a room, where temperature falls within appropriate climatic class stated on the data plate. The operation of the device may worsen when it shall operate in temperature lower or higher than the stated temperature range.



## Remarks and indications

- It is necessary to properly level the rack, which will prevent the device from noisy operation and will ensure proper outflow of the water (condensate) during defrosting.
- After transporting the device, wait about 2 hours before its actuation.
- In order to ensure proper conditions for the stored products, do not load the shelves completely. It is necessary to ensure even load of shelves and not to exceed the maximum load.
- The first filling of cooling space should be performed after its previous cooling to working temperature. This principle should also be observed after longer pause in exploitation.
- Do not block any ventilation holes, which would hamper circulation of the cooled air (Do not place the products directly to the screen!). It is also necessary to ensure proper airflow around the device (aggregate ventilation holes cannot be covered).
- Keep the condenser clean. Impurities may lead to overheating of the compressor and as a consequence may result in damage of the device, which is not covered by warranty.
- Do not use electric devices inside grocery product storing chamber.
- When the rack is used without the need to display goods (night work; closed post, shop) it is recommended to drop roller blinds in order to reduce consumption of electric energy

## 4.1. Temperature regulation



Service of "Igloo" and "Carel" thermostat (temperature regulators) is described in chapter 7 (p.20 and 21)

The basic aim of a thermostat is to control the cooling aggregate to obtain the set temperature within the device and maintain it within the determined temperature ranges. The producer enters all settings of temperature regulators required for normal functioning of the device. Before primary actuation the user should control and possibly set the required temperature inside the device on the control panel.

Digital display – displays the current temperature inside the device.



It is forbidden to interfere with systemic parameters of the thermostat, as this can lead to serious consequences, including the damage of the cooling device!

## 5. MAINTENANCE

### 5.1. Cleaning and maintenance



All maintenance services need to be performed after disconnecting the device from power supply!



Protect electric installation against any damage or water spillage



Do not use water stream to clean the device, only a wet cloth



Do not use any sharp objects to remove filth!

If the device is not equipped with automatic condensate evaporation, it is necessary to remove the condensate from the container when it is full Fig.9 (p.17). Frequency of removing condensate (number of removals) depends on device operating conditions (among others on air humidity, amount and temperature of placed products).



When using the display cabinet, as well as during maintenance works, pay attention not to destroy the temperature sensor in the evaporator screen!

It is recommended to make a break in the exploitation of the device once a month in order to clean its interior, naturally defrost the evaporator and clean the condenser.

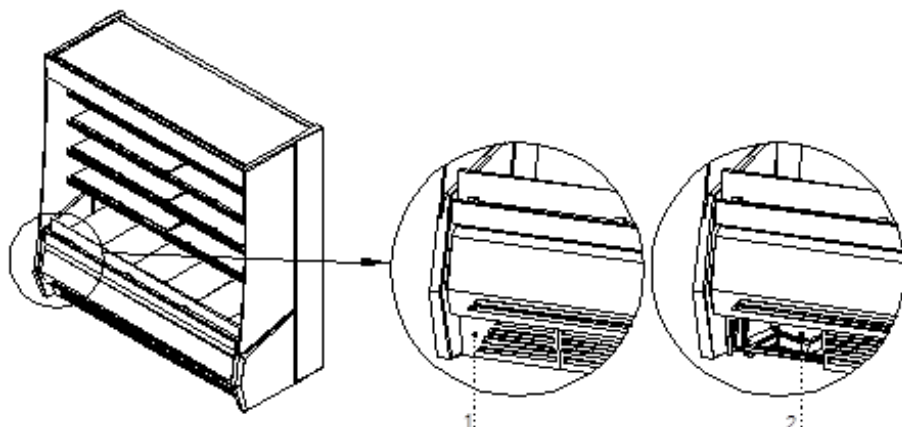

**Fig.9 Condensate container**

1. Lower left ventilator (after removal access to the condensate container)
2. Condensate container (applies to the version without the evaporator!)

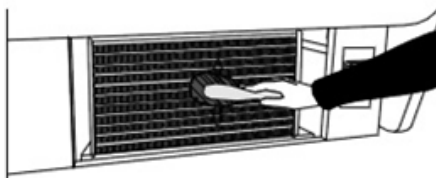

**Fig.10 Cleaning the condenser**



The producer shall not be held responsible for damages of the condenser aggregate resulting from non-observance of condenser cleanliness!



Do not use mechanical agents to quicken the defrosting process!

It is essential to keep the condenser of the device clean. Dirt may hinder the heat exchange, causing mainly increase in electric energy consumption and may cause damage of aggregate compressor.

In order to clean the condenser it is necessary to unscrew the sheet metal screws and pull the wind brace out of catch by lifting it up. Clean condenser lamellas with help of soft brush or paint brush. If the condenser is extremely dirty (blocking of lamellas) it is indicated to use vacuum cleaner or compressed nitrogen to suck / blow the dirt from between lamellas.

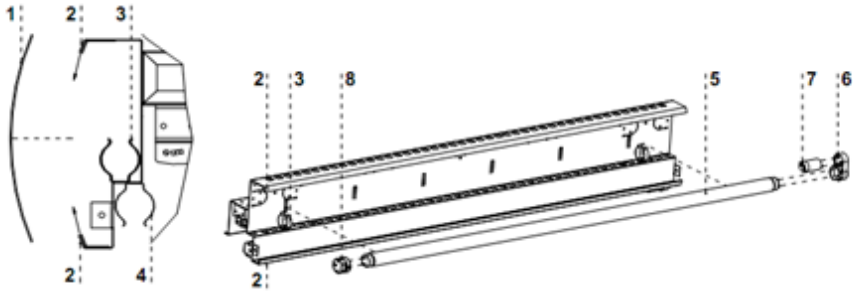

**Fig.11 Changing the fluorescent lamp**

- 1 – Upper panel plexiglas
- 2 – Plexiglas fixing handles
- 3 – Fluorescent lamp handle (upper panel lighting)
- 4 – Fluorescent lamp handle (upper lighting, internal)

- 5 – Fluorescent lamp
- 6 – Casing of the fluorescent lamp and starting switch
- 7 – Fluorescent lamp starting switch
- 8 – Casing of the fluorescent lamp



**Elements of device can corrode when improper used and maintenance. To avoid that please follow the rules:**

- Do not allow contact of the surface of the device with substances containing chlorine and / or baking soda in different varieties, which destroy the protective layer and components of the device (also includes various stainless steel)



During maintenance services it is necessary to pay attention not to damage the data plate of the device Fig.13 (p.20), which contains significant information for servicing organs and waste removal companies.

## 6. SERVICE

### 6.1. Fault identification and repair

In case of any difficulties during actuation of the device or during its exploitation, please return to these chapters in this manual, which explain the performed operation. This aims to ensure that the device is properly operated. If you still experience difficulties, the following hints will help you solve the problem.

**The device is not working... – Make sure that:**

- The device is connected to the supply network
- Voltage and frequency in the network are compliant with those recommended by the producer, 230V/50Hz
- The main switch is turned on
- Thermostat is turned on (This concerns the Igloo thermostat – If only two spots are visible on the display – turn on the thermostat)

**The device is operating, but the lighting is off...– Make sure that:**

- Lighting switch is turned on
- Fluorescent lamp or starting switch of the device are not burnt

**Water leakage from under the device**

- Check whether the device is properly levelled
- Empty the condensate container

**The device does not reach the proper temperature, the lighting is on...– Make sure that:**

- The main switch is on
- Temperature setting on the thermostat is properly set
- Thermostat works properly
- The condenser is clean, if necessary – clean the condenser
- Ambient temperature does not exceed 25°C



- Enough time has passed for products to be cooled
- Ventilation holes of the device are not blocked

**(This concerns the “IGLOO” thermostat) thermostat displays C0 or C1 or C2 instead of displaying temperature: This situation shall occur, when one of temperature regulation sensors has been destroyed. The following messages may be displayed in such case:**

- C0 – temperature sensors inside the chamber are damaged – call authorized service
- C1 – failure of evaporator sensor - call authorized service
- C2 – failure of condenser alarm sensors (or failure of second evaporator sensor) – call authorized service

**(This concerns the “CAREL” thermostat) Thermostat displays E0 or E1 or L0 or HI or EE or Ed or DF instead of temperature:**

- E0 – failure of temperature sensor inside the chamber – call authorized service
- E1 – failure of evaporator sensor – call authorized service
- L0 – low temperature alarm (lower than temperature range set within the device – call authorized service
- HI – high temperature alarm – call authorized service
- EE – internal defect of the regulator – call authorized service
- Ed – max. defrosting time exceeded
- DF – defrosting in progress (this is not an alarm signal)

**(This concerns the “IGLOO” thermostat) The device is working, sound signalling is activated...– Make sure that:**

- The condenser is clean, if necessary – clean the condenser
- Condenser ventilator is working properly
- Ambient temperature does not exceed 25°C

**The device is working too loud...– Make sure that:**

- The device is standing stably and is properly levelled
- Furniture adjoining the device do not vibrate when the cooling aggregate compressor is working



Noises made by the operating device are a normal phenomenon. The devices are equipped with ventilators, engines and compressors, which turn on and off automatically. **Each compressor makes certain noises when operating. These sounds are made by the aggregate engine and by cooling agent flowing through the circuit. This phenomenon constitutes a technical feature of cooling devices and it does not signify their faulty work.**



Steam precipitation on glasses of the device is a normal phenomenon in case of high relative air humidity exceeding 60% and does not require calling the service

**6.2. Service**

IGLOO service telephone number: +48 (14) 662 19 56 or +48 605 606 071 e-mail: [serwis@igloo.pl](mailto:serwis@igloo.pl)

If after checking points described in chapter 6.1 “Fault identification and repair” the device still does not work properly, please contact Technical Service of the Igloo company, stating the data from the data plate Fig.13 (p.10)



**Fig.12 Data plate**

- Serial number (NS)
  - Production date
  - Type (name of the device)
- and
- Date when the device was purchased
  - Description of the problem
  - Your exact address and telephone number (with the code number)

- The data plate is located inside the device, on the screen, in its right upper corner



The above figure shows a demonstrative data plate and the data stated on the plate are exemplary data, which are not related with Timor device!

## 7. THERMOSTAT SERVICE

### 7.1. „IGLOO” thermostat

Fig.13 „Iglloo” thermostat control panel

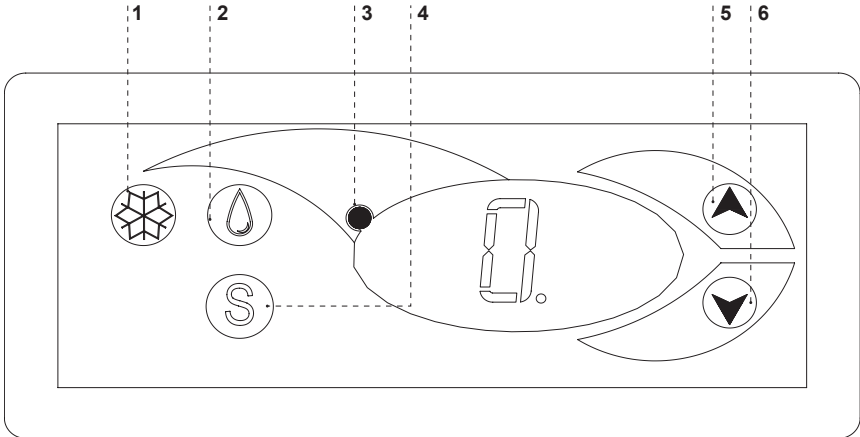

- 1 – Cooling on/off switch
- 2 – Manual defrosting switch
- 3 – Aggregate and defrosting operating control diode
- 4 – Temperature monitoring switch on defrosting sensor
- 5 – Temperature regulation switch (increase)
- 6 – Temperature regulation switch (decrease)

Verification of adjusted temperature (inside the device) – By pressing “▲” or “▼” switch once we can verify the adjusted temperature. The adjusted temperature shall be shown on the display with a visible red blinking spot (diode). The preview shall finish automatically after about 3 seconds.

Lowering (or increasing) the temperature – press “▼” (or “▲”) switch and the adjusted temperature shall be visible on control panel. By pressing the “▼” switch we decrease the temperature to the desired value. The preview shall finish automatically after about 3 seconds.

Manual defrosting – switch No. 2 enables to initiate the defrosting cycle at any moment when the device is working (regardless of the automatic defrosting function); the switch shall not operate when the temperature is higher than the final defrosting temperature.



The user should switch on/ switch off the aggregate only by means of the main switch of the device, and not by means of the direct switch on thermostat control panel. Switching on the main switch shall automatically initiate the thermostat!

\* Read more on [www.igloo.pl](http://www.igloo.pl)

7.2. „CAREL” thermostat

Fig.14 „Carel” thermostat control panel

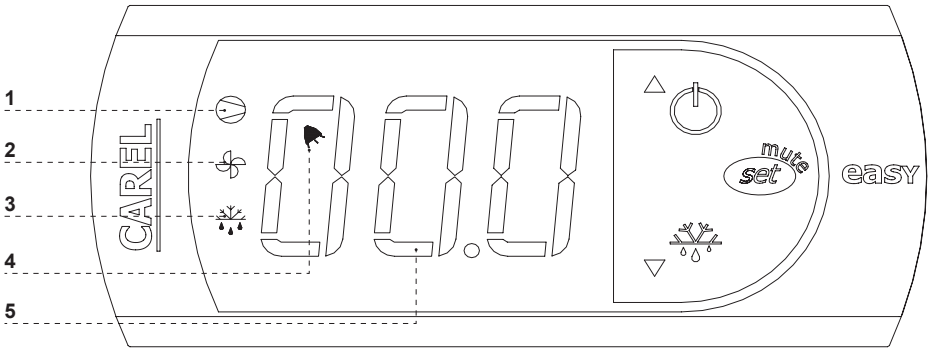

WHAT DO DIODES ON CONTROL PANEL SIGNIFY

**Diode 1 is on - Compressor:** the symbol is visible when the compressor is working. It is blinking when compressor actuation is delayed by security procedure. It blinks in the following cycle: two blinks – pause, when the constant working mode is activated.





**Diode 2 is on - Ventilator:** the symbol is visible when evaporator ventilators are turned on. It blinks when the actuation of the ventilators is delayed by external disengagement or when another procedure is in progress.

**Diode 3 is on - Defrosting:** the symbol is visible when the defrosting function is activated. It blinks when the actuation is delayed by external disengagement or when another procedure is in progress.

**Diode 4 is on - Alarm:** the symbol is visible when the alarm is activated.

5 – current temperature inside the device is displayed (decimal places displayed after the comma)

SETTING THE DESIRED TEMPERATURE

- press for 1 second  leading value shall be displayed on the screen;
- increase or decrease the leading value by means of  and , switches, until the desired value shall be obtained;
- press  once again in order to confirm the new value of the setting point;

MANUAL INPUT OF THE DEFROSTING CYCLE

Defrosting shall be realised in an automatic mode. It is possible to force defrosting at any moment by pressing and holding the  switch for minimum 5 seconds. Diode No. 1 shall blink during manual defrosting.

\* Read more on [www.alfaco.pl](http://www.alfaco.pl)

NOTE: IN CASE OF NOT OBSERVING THE PRINCIPLES ON CONNECTING AND USING THE DEVICE INCLUDED IN THIS MANUAL, THE PRODUCER SHALL RESERVE THE RIGHT TO RECEDE FROM OBLIGATIONS OF THE GUARANTOR!!!

Information included in this document may be altered by “IGLOO” without noticing the user.  
 Copying the present manual without the consent of the producer is forbidden.  
 Images and drawings are of demonstrative character and may differ from the purchased device.